

MODEL R210s



TECHNICAL SPECIFICATIONS



Dynamic, Accurate, Solid. The audiophile's choice. Where sound quality and Transients free of overhang are paramount. Only bettered by our upscale D-Series subs. Ground up drivers developed by our team of engineers. Glass fiber composite diaphragms, multiple aluminum shorting rings, massive magnets, multi-layer Nomex spiders and lightweight aluminum voice coil wire are the key ingredients - Proprietary nonlinear modeling techniques allow us to simulate all these components and then optimize for real world driver performance - free air and in box. Further refinement is done with the aid of Klippel laser measurements to dial things in. To take performance to another level, the push-pull drivers reduce even order harmonics distortion by an additional 10-12dB. Powered by our 1.3kW amplifier, all functions and safeties are controlled by a 48-bit data bath DSP and 32-bit ARM M4 Cortex processor, able to react in microseconds, powerful enough to slam. All R-Series subs share our 2.4" LCD touchscreen display and ability to control advance settings using our App. Certified by THX Dominus

BASIC

Dimensions (HxWxD)
545 x 380 x 450mm
21.5 x 15.0 x 17.7"

Weight
44.0 kg (96.8 lbs.)

Available finishes
Piano Gloss Black

TECHNICAL

Alignment
Push-Pull, acoustic suspension

Amplifier
1.3kW rms short term

Display Interface
2.4" LCD color touchscreen

App
iOS and Android

Processor
32-bit ARM Cortex M4, double precision floating point math

DSP Engine
Ti DSP 48-bit data paths

Driver complement
(2)250mm, Glass fiber diaphragm +/-20mm linear excursion

Frequency Response

- THX EQ
20-290Hz (-6dB) / 16-302Hz (-10dB)
- Boost (Large Room) EQ
16-290Hz (-6dB) / 14-302Hz (-10dB)

- Cut (Small Room) EQ
25-290Hz (-6dB) / 19-302Hz (-10dB)

Inputs
(2) Balanced XLR
(2) Unbalanced RCA

Outputs
(2) Balanced XLR unbuffered
(2) Unbalanced RCA unbuffered

Parametric EQ
10-Band PEQ with 3 user presets

Low Pass filter
bypass, 30-160Hz, slope 6,12,18,24dB/oct

Phase
Variable 0-270°

Polarity
normal / inverted

Configurable Auto turn-on and 12v Trigger
XLR 1, XLR 1+2, RCA 1, RCA 1+2

Certification
THX Dominus (4), THX Ultra (1)



App Control
iOS and Android

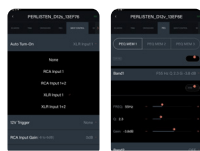

Advanced APP User interface
Customizable turn-on controls and input selection, multiple PEQ's with presets

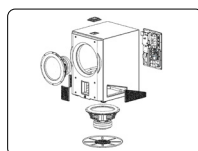

Push-Pull - Asymmetrical
Distortion killer

4 3 2 1

REVISIONS		DATE
REV.	DESCRIPTION	
1	Initial Release	1/5/2022

D C B A

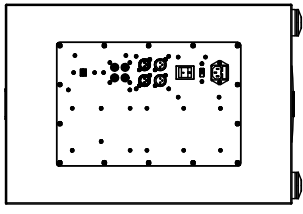
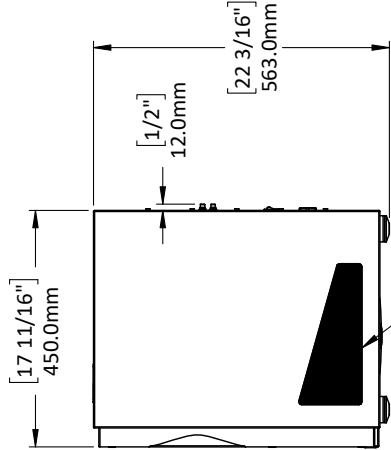
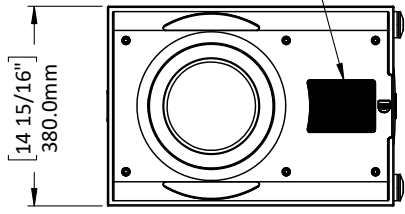
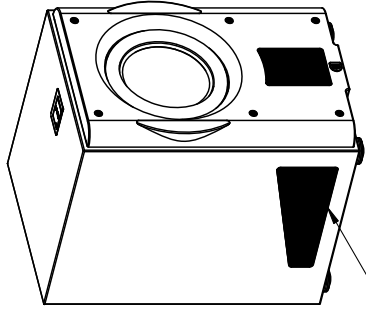
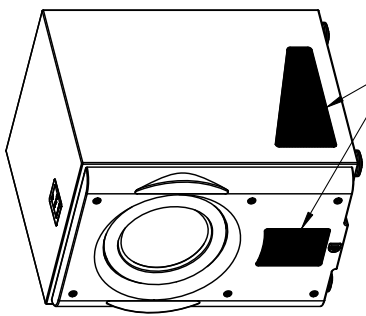
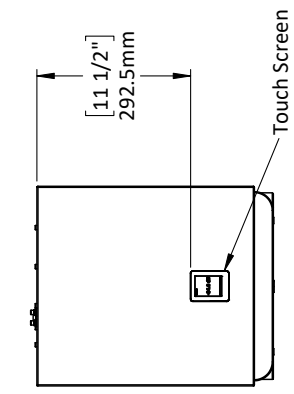

NAME	DATE	 <small>PERLISTEN AUDIO, LLC</small>
TITLE:		SIZE DWG. NO. A PL_R210s_Architectural REV 1
Sheet1		
SCALE: 1:12		SHEET 1 OF 1

PROPRIETARY AND CONFIDENTIAL
 THE INFORMATION CONTAINED IN THIS DRAWING IS THE SOLE PROPERTY OF PERLISTEN AUDIO, LLC. ANY REPRODUCTION OR TRANSMISSION OF THIS DRAWING WITHOUT THE WRITTEN PERMISSION OF PERLISTEN AUDIO, LLC IS PROHIBITED.
DATE PLOTTED: 1/5/2022 10:58:23 AM
 USER: JACOB

D

C

B

A

2 1